

**EH2400  
Indoor Enclosure**

**Installation/  
Operation Manual**

**C1468M (7/97)**

---

---

# CONTENTS

---

---

<b>Section</b>	<b>Page</b>
1.0 GENERAL .....	1
1.1 IMPORTANT SAFEGUARDS AND WARNINGS .....	1
2.0 DESCRIPTION .....	2
3.0 INSTALLATION .....	3
3.1 FLUSH CEILING OR MID-WALL CORNER MOUNT .....	3
4.0 MAINTENANCE .....	4
5.0 MECHANICAL PARTS LIST .....	5
6.0 SPECIFICATIONS .....	6
7.0 WARRANTY AND RETURN INFORMATION .....	8

## LIST OF ILLUSTRATIONS

<u>Figure</u>	<u>Page</u>
1 EH2400 Dimension Drawing .....	7

## REVISION HISTORY

<u>Manual #</u>	<u>Date</u>	<u>Comments</u>
C1468M	7/97	Original version.

(This page intentionally left blank.)

---

---

## 1.0 GENERAL

---

---

### 1.1 IMPORTANT SAFEGUARDS AND WARNINGS

Prior to installation and use of this product, the following WARNINGS should be observed.

1. Installation and servicing should only be done by Qualified Service Personnel and conform to all Local codes.
2. Unless the unit is specifically marked as a NEMA Type 3, 3R, 3S, 4, 4X, 6, or 6P enclosure, it is designed for indoor use only and it must not be installed where exposed to rain and moisture.
3. Only use replacement parts recommended by Pelco.
4. After replacement/repair of this unit's electrical components, conduct a resistance measurement between line and exposed parts to verify the exposed parts have not been connected to line circuitry.
5. The installation method and materials should be capable of supporting four (4) times the weight of the enclosure, pan/tilt, camera and lens combination.

#### The product and/or manual may bear the following marks:



This symbol indicates that dangerous voltage constituting a risk of electric shock is present within this unit.



This symbol indicates that there are important operating and maintenance instructions in the literature accompanying this unit.

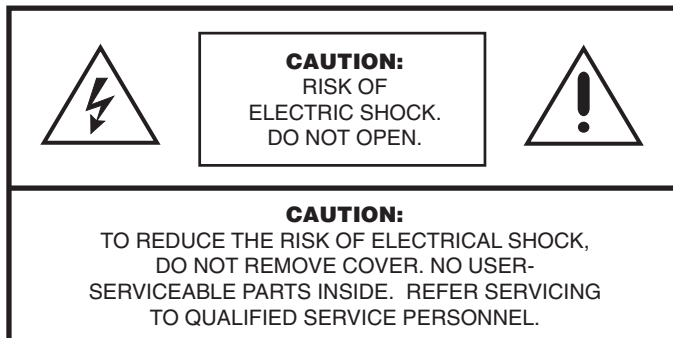

**Please thoroughly familiarize yourself with the information  
in this manual prior to installation and operation.**

---

---

## 2.0 DESCRIPTION

---

---

The EH2400 medium security camera housing is designed to provide a low cost, tamper resistant corner mount for fixed camera applications. The EH2400 may be installed flush against a ceiling, or mid-wall, in high ceiling applications, without compromising enclosure integrity. The smaller frontal area and reduced overall size create an unobtrusive enclosure that is ideal for today's smaller cameras. The EH2400 will accommodate Pelco box cameras with vari-focal lenses that do not exceed 8-inches (20.32 cm) in total length. Three conduit knockouts allow wires to be delivered from the wall (either side) or ceiling.

Included in this package:

- 1 5/32-inch tamper resistant L key (p/n ZTHEXKEY5/32)
- 1 Camera mounting screw, 1/4-20 x .375 phillips pan head (p/n ZH1/4-20X.375SPP)

---

---

## 3.0 INSTALLATION

---

---

**NOTE:** *The fasteners required to secure the EH2400 (minimum 1/4-20 recommended) are not supplied.*

Before mounting the EH2400, make certain that the mounting surface is capable of supporting the weight of the enclosure plus camera and lens.

Determine the location of the enclosure and means of delivering all necessary cabling before beginning the installation process. Knockouts that will accommodate 1/2-inch or 3/4-inch conduit have been provided on both wall mounting surfaces and the ceiling surface.

### 3.1 FLUSH CEILING OR MID-WALL CORNER MOUNT

To install the EH2400 do the following:

1. Remove the two (2) tamper resistant screws on the underside of the housing (using the hex key included in this package) and separate the cover from the mounting bracket. Remove the tilt table assembly.
2. Remove the appropriate knockout according to your installation and/or conduit connection.
3. Using the mounting bracket, mark and drill holes in the mounting surface.
4. If you are using conduit to route cabling to the enclosure, complete that portion of the installation at this time, including routing all cabling.
5. Attach the enclosure with the required fasteners.
6. Mount the camera/lens to the tilt table assembly. Install the completed assembly onto the mounting bracket.
7. Make all camera/lens connections and adjust the tilt table assembly and camera lens as necessary.
8. Replace the cover. Check that all components clear the cover and that camera angle and lens adjustments are satisfactory. When all adjustments are complete, secure the cover with the provided hex key.

---

---

## **4.0 MAINTENANCE**

---

---

Clean the window regularly to help maintain picture clarity. Use a soft cloth and a mild nonabrasive detergent.



---

---

## 5.0 MECHANICAL PARTS LIST

---

---

Item No.	Qty	Description	Part Number
1	1	Mounting bracket weld assembly	EH24001001WA
2	1	Cover weld assembly	EH24001000WA
3	1	Window	EH240010000
4	2	Button head tamper proof screw	ZH1/4-20Z.50TSS
5	5	4-40 hex nut, stainless steel	ZH4-40NUTSH
6	5	Flat washer, stainless steel	ZH125X312X32S
7	1	Tilt table support leg	DF54001COMP
8	1	Tilt table	DF54002COMP
9	2	1/4-20 hex nut, stainless steel	ZH1/4-20NUTCH
10	2	1/4" split lock washer, SS	ZH1/4LWSSL
11	2	Fender washer	ZH255X1.50X62

---

---

## 6.0 SPECIFICATIONS

---

---

### **MECHANICAL**

Camera Mounting: Adjustable tilt table

Maximum Camera/  
Lens Size: Accommodates camera/lens combinations (including BNC connector) up to:  
8.0" L x 4.0" W x 4.0" H (20.32 cm x 10.16 cm x 10.16 cm)

Viewing Window: 3/16" (4.76 mm) thick, optically clear, impact resistant Lexan™ MR5 coated (UL 94HB rated).

Window  
Viewing Area: 4.25" x 2.56" (10.8 cm x 6.50 cm)

Cable Entry: Ø.875-inch or Ø1.125-inch knockout access through rear walls and top

Enclosure  
Mounting: Eight (8) Ø.250-inch on protected rear surfaces

### **GENERAL**

Construction: 1/8" aluminum

Finish: Gray polyester powder coat

Dimensions: See Figure 1

Environment: Indoor

Unit Weight: 6.4 lbs (2.9 kg)

Shipping Weight: 9 lbs (4.07 kg)

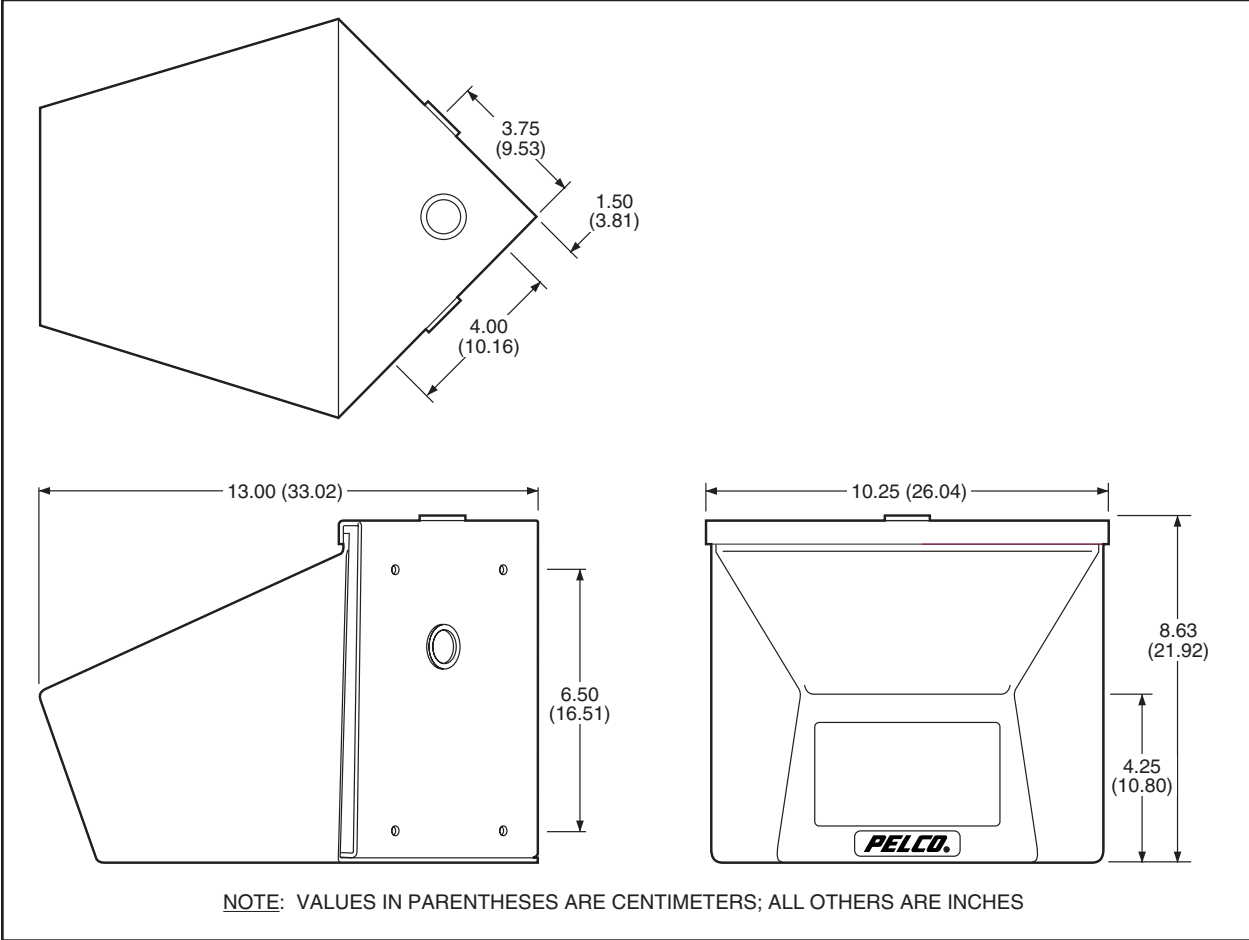

**Figure 1.** EH2400 Dimension Drawing

---

---

## 7.0 WARRANTY AND RETURN INFORMATION

---

---

### WARRANTY

Pelco will repair or replace, without charge, any merchandise proved defective in material or workmanship for a period of one year after the date of shipment.

Exceptions to this warranty are as noted below:

- Five years on FT/FR8000 Series fiber optic products.
- Three years on Genex® Series products (multiplexers, server, and keyboard).
- Three years on Camclosure® and fixed camera models, except the CC3701H-2, CC3701H-2X, CC3751H-2, CC3651H-2X, MC3651H-2, and MC3651H-2X camera models, which have a five-year warranty.
- Two years on standard motorized or fixed focal length lenses.
- Two years on Legacy®, CM6700/CM6800/CM9700 Series matrix, and DF5/DF8 Series fixed dome products.
- Two years on Spectra®, Esprit®, ExSite™, and PS20 scanners, including when used in continuous motion applications.
- Two years on Esprit® and WW5700 Series window wiper (excluding wiper blades).
- Eighteen months on DX Series digital video recorders, NVR300 Series network video recorders, and Endura™ Series distributed network-based video products.
- One year (except video heads) on video cassette recorders (VCRs). Video heads will be covered for a period of six months.
- Six months on all pan and tilts, scanners or preset lenses used in continuous motion applications (that is, preset scan, tour and auto scan modes).

Pelco will warrant all replacement parts and repairs for 90 days from the date of Pelco shipment. All goods requiring warranty repair shall be sent freight prepaid to Pelco, Clovis, California. Repairs made necessary by reason of misuse, alteration, normal wear, or accident are not covered under this warranty.

Pelco assumes no risk and shall be subject to no liability for damages or loss resulting from the specific use or application made of the Products. Pelco's liability for any claim, whether based on breach of contract, negligence, infringement of any rights of any party or product liability, relating to the Products shall not exceed the price paid by the Dealer to Pelco for such Products. In no event will Pelco be liable for any special, incidental or consequential damages (including loss of use, loss of profit and claims of third parties) however caused, whether by the negligence of Pelco or otherwise.

The above warranty provides the Dealer with specific legal rights. The Dealer may also have additional rights, which are subject to variation from state to state.

If a warranty repair is required, the Dealer must contact Pelco at (800) 289-9100 or (559) 292-1981 to obtain a Repair Authorization number (RA), and provide the following information:

1. Model and serial number
2. Date of shipment, P.O. number, Sales Order number, or Pelco invoice number
3. Details of the defect or problem

If there is a dispute regarding the warranty of a product which does not fall under the warranty conditions stated above, please include a written explanation with the product when returned.

Method of return shipment shall be the same or equal to the method by which the item was received by Pelco.

### RETURNS

In order to expedite parts returned to the factory for repair or credit, please call the factory at (800) 289-9100 or (559) 292-1981 to obtain an authorization number (CA number if returned for credit, and RA number if returned for repair).

All merchandise returned for credit may be subject to a 20% restocking and refurbishing charge. Goods returned for repair or credit should be clearly identified with the assigned CA or RA number and freight should be prepaid. Ship to the appropriate address below.

If you are located within the continental U.S., Alaska, Hawaii or Puerto Rico, send goods to:

Service Department  
Pelco  
3500 Pelco Way  
Clovis, CA 93612-5699

If you are located outside the continental U.S., Alaska, Hawaii or Puerto Rico and are instructed to return goods to the USA, you may do one of the following:

If the goods are to be sent by a COURIER SERVICE, send the goods to:

Pelco  
3500 Pelco Way  
Clovis, CA 93612-5699 USA

If the goods are to be sent by a FREIGHT FORWARDER, send the goods to:

Pelco c/o Expeditors  
473 Eccles Avenue  
South San Francisco, CA 94080 USA  
Phone: 650-737-1700  
Fax: 650-737-0933

Pelco, the Pelco logo, Camclosure, Esprit, Genex, Legacy, and Spectra are registered trademarks of Pelco.  
Endura and ExSite are trademarks of Pelco.

© Copyright 1999, Pelco. All rights reserved.